

BGR Components and Model Identification

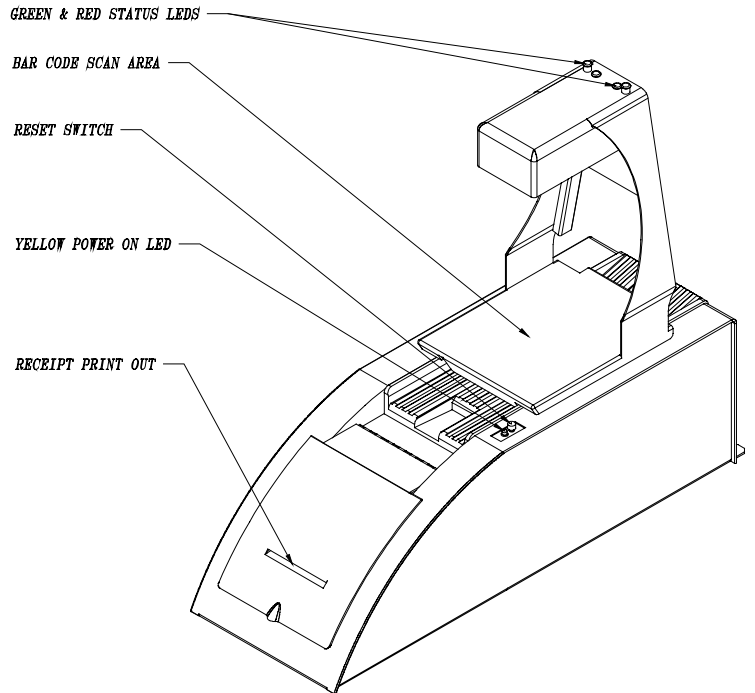

EC2000se Model Identification

An EC2000SE can generally be identified by a Rectangular logo (as shown here), or by the 81U-16xx-xxxK part number on the agency or back panel ratings label.



ATB Coupon Insertion

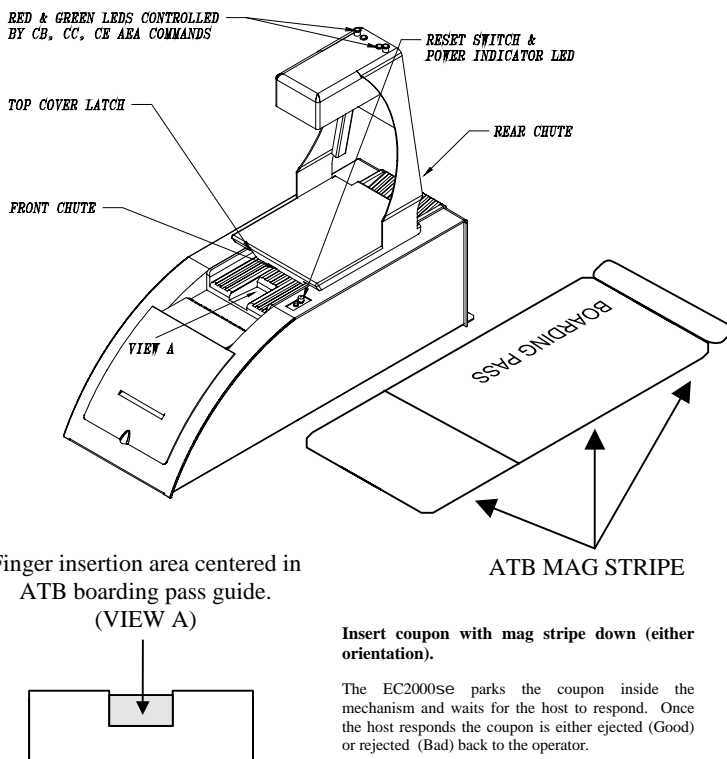

Reading Bar Codes

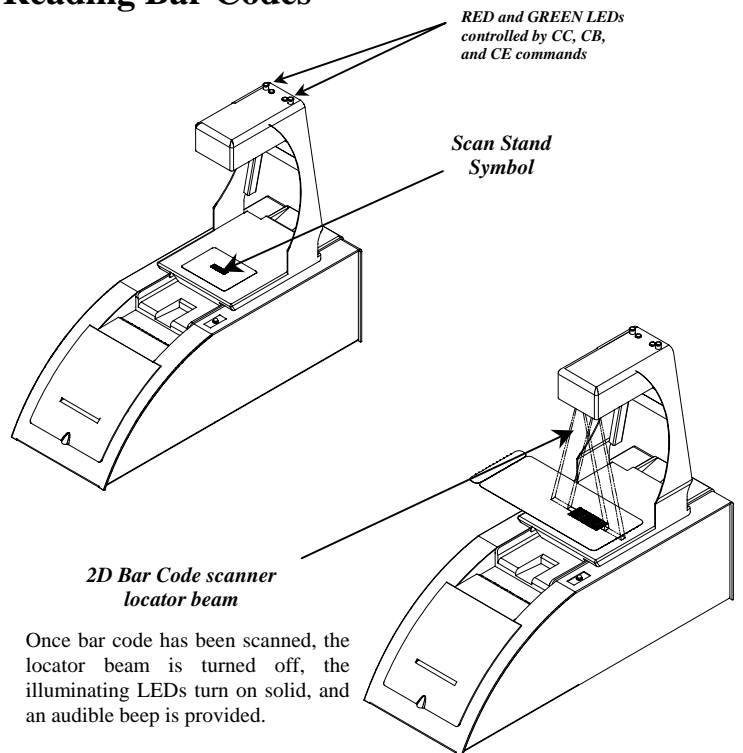

Clearing Jams

Occasionally, an ATB coupon will become jammed, especially in cases where multiple coupons get accidentally inserted or a coupon is accidentally folded over as shown below.

If an ATB coupon becomes jammed, perform the following steps to clear the Unit:

1. Press the reset switch and see if the Unit can automatically clear itself. Remove the rejected coupon.
2. Move the top cover latch to the right and swing cover open (top cover may include a mounted bar code scanner).
3. Push down on the idler support latches (one on each side of the idler assembly).
4. Swing the idler assembly up and against the top cover.
5. Remove the ATB coupon.
6. Verify that all idler and pressure rollers turn smoothly and spring up/down freely.
7. Close the idler assembly (by latching both sides) and the top cover to continue with operation.
8. **DO NOT** pull on the springs securing/mounting the mag head pressure rollers.

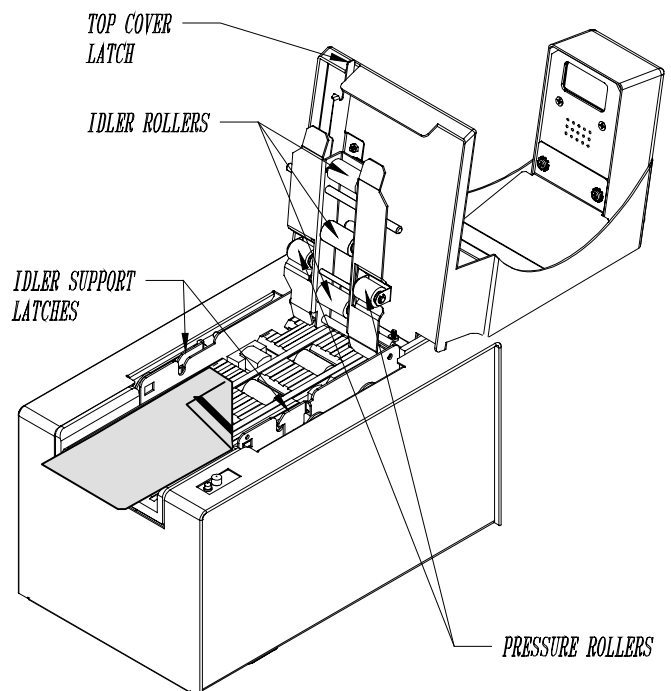

Receipt Stock Loading

To access the receipt printer, lift up on the outer door and rotate it past 90°.

Verify that the thermal surface of the roll stock is facing down toward the bottom of the Unit.

Set the roll down in the paper roll reservoir and then insert the free end of the roll into the paper feed slot at the top of the printer assembly.

The receipt printer will automatically detect the stock, pull the stock into the print mechanism and through the cutter mechanism.

After feeding a default distance, the cutter will activate and perform a full cut.

Remove the excess stock (previously cut off) and close the outer door. Make sure that the door closes securely (door will latch in place).

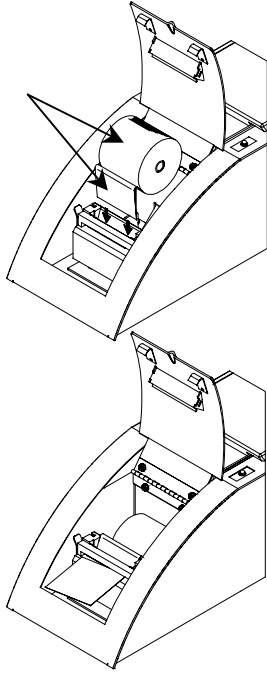

Cleaning the Receipt Printer

Turn the Unit off before attempting any cleaning procedure on the receipt printer.

Use a cleaning solution of 99% Isopropyl Alcohol and a lint free cloth or swab.

NEVER use a water based solution to clean the printers platen roller. Some water based solutions can damage the Platen.

1. Open the access door on the Unit and flip the cutter mechanism down.
2. Flip the green print head lever and release it from the platen roller. Use the green knob and rotate the platen roller looking for pieces of label stock. Clean the platen roller using the cleaning solution and cloth or swab.
3. Using the green lever, flip the print head back against the platen roller.
4. Check the cutter mechanism for pieces of label stock. Wipe the mechanism with a lint free cloth or swab. It is not recommended to use any kind of cleaning solution on the cutter mechanism.

If the cutter blade is not in the lower (home) position or appears to be stuck, you may use the gear knob in the front of the cutter (identified by an up and down arrow) to manually move the blade. Rotate the gear knob using a small flat blade screwdriver. When the Unit is powered on, the cutter should automatically reset to the home position.

The knob is geared so that you must turn it multiple times to move the blade only a very slight amount.

Cleaning the ATB Mag Reader

When cleaning the Unit's ATB MAG Reader, the only acceptable cleaning solution is 99% Isopropyl Alcohol.

NEVER use a water based solution to clean the Unit's rollers or read heads. Some water based solutions can damage the rubber elastomer on the rollers.

Be very cautious about cleaning pouches like the ones used to clean PC screens. The solution for this type of cleaning pad is typically 50% water and 50% Isopropyl Alcohol and is unacceptable.

Use Unimark ATB cleaning cards (P/N 700-5014-000, -200 or equivalent), which are presoaked in a solution of 99% Isopropyl Alcohol.

To clean the ATB MAG Reader option:

1. Locate the Unit and make sure it is powered on and ready to accept an ATB coupon (this may require host setup to enable the ATB Mag input; look for display messages like Shutter closed, Link down, or Insert Coupon)
2. Tear open the ATB cleaning card pouch
3. Insert cleaning card as though it were an ATB coupon to be read
4. Flip the card over and reinsert the cleaning card again
5. Repeat a couple more times

The cleaning card will dry out very quickly with 99% Isopropyl Alcohol. Do not insert the cleaning card dry.

Cleaning the Bar Code Scanner Lens

As a general rule, the bar code scanner option should require very little cleaning. The 2D scanner components are enclosed to minimize effects from the environment.

The primary item requiring cleaning is the scanner lens. The lens prevents access to the image engine. The lens can become dirty from environmental dust and smudged by operators touching the lens.

To clean the lens:

1. Locate a soft non-abrasive/lint free cloth.
2. Wipe the lens area (refer to the diagram for lens location).
3. If some particles continue to cling to lens area, use canned air to dislodge and clear them away.

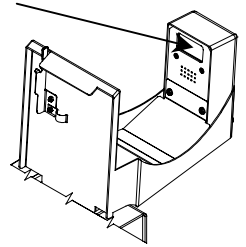

DO NOT use a cloth soaked in any cleaning agent. Some cleaning agents can attack the plastic lens material and cause it to become cloudy instead of transparent. Using an abrasive cloth can scratch the lens, and a cloth that is not lint free may cause more material to be collected on the lens than what was originally present.

Basic Troubleshooting

The following section is provided to assist in the installation of the Unit, and covers the issues which commonly exist when installing new equipment.

1.0 Unit will not power up

- 1.1 Verify AC plug is installed into the rear of the Unit.
- 1.2 Check the AC line level. The Unit is designed to operate at voltages as low as 90VAC.

2.0 Unit will not communicate with the host system

- 2.1 Verify comm. cable is plugged into connector marked HOST on the rear of the Unit.
- 2.2 Verify that the comm. parameters of the host system match the Unit's host port parameters.

3.0 Unit will not recognize a coupon when inserted into the ATB MAG read slot

- 3.1 Verify that the optical sensor in the front of the ATB MAG read slot is not exposed directly to sunlight. Relocate the Unit if necessary.
- 3.2 Verify that the optical sensor is free of foreign material. Clear sensor if blocked.
- 3.3 The EC2000SE also incorporates a rear sensor which must be clear for stock to be properly recognized and processed.

4.0 Cannot read the display

- 4.1 Verify that the display is not exposed directly to sunlight. LCD displays can be difficult to see in sunlight. Relocate the Unit if necessary. Vacuum Florescent displays are more visible in brightly lighted areas.
- 4.2 Shade the display with your hand. If the display still cannot be seen, return the Unit to Unimark or a certified service center.

5.0 Optional Internal bar code scanner will not transmit data, appears to be off, or flashes continuously

- 5.1 If the bar code scanner was installed at the airport site location, it is possible that the communication parameters are not set. Use the configuration bar codes in the operator's manual to establish the minimum parameter settings to allow the scanner to communicate with the Unit.

- 5.2 If the bar code scanner illumination LEDs flash continuously or erratically, it may not be locking onto the scan stand symbol:
 - 5.2.1 Clean the scanner lens.
 - 5.2.2 Verify that the scan stand symbol label is intact below the scanner mount.
 - 5.2.2 Verify that the scan stand symbol label is clean and has not been marked up (label is white background with a 1D style symbol centered onto the surface). Clean the label with a 50% alcohol and 50% water mixture or equivalent cleaner. Replace label if necessary (Unimark P/N 740-5040-200).
- 5.3 If the scanner appears to be powered off:
 - 5.3.1 Cover the scan stand symbol on the white label below. This should cause the scanner to turn on (flash) its illumination LEDs so the scanner can read a bar code.
 - 5.3.2 If the LEDs do not turn on, remove the cable cover/clamp.
 - 5.3.3 Remove the bar code scanner and verify the interface connection.
- 5.4 If the scanner reads bar codes randomly, the scanner lens may be dirty or smudged. Locate the scanner lens area (as shown below) and clean with a soft non-abrasive/lint free cloth.